

**halliday
baillie**

HB 1220

RECESSED SINGLE BLIND BOX EXTRUSION

Full Blind Box Extrusion is a sleek extrusion mounted flush to ceiling gib (10mm or 13mm), primarily for automated blinds and screens.

Full Box Blind Extrusion – sold in 3m lengths only.

Materials: Extruded Aluminium, available either in raw unfinished aluminium or anodised. Raw extrusion can be powdercoated or custom finished.

Please note: blinds and any automation mechanisms not included. If specifying for manual blinds, the cover flap will need to be made approximately 30mm shorter at each end to allow for cord access. This is the responsibility of the client.

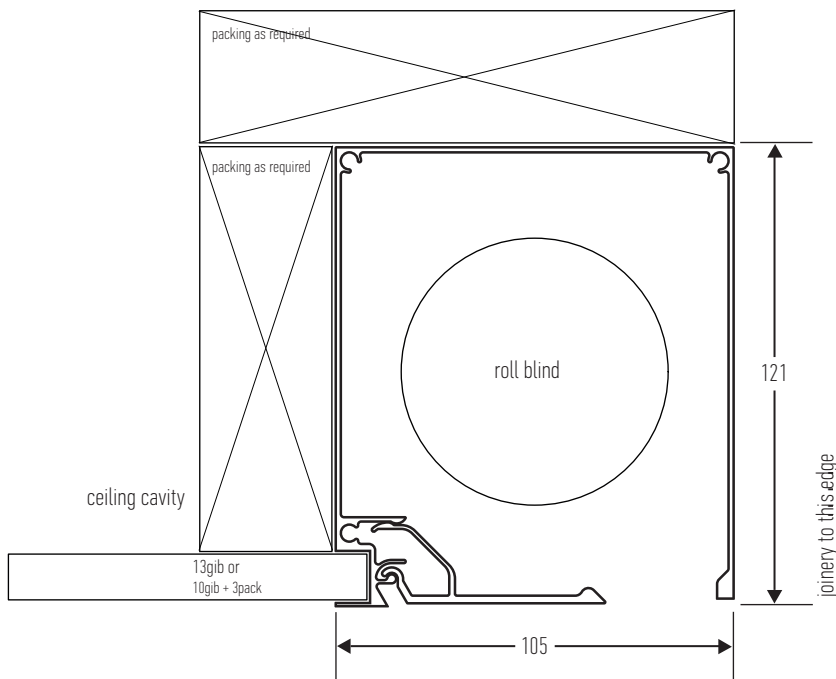

Designed and made in New Zealand. For more information, installation templates, and measured drawings of this product and others please visit : www.hallidaybaillie.com or contact your authorized Halliday + Baillie dealer. All information subject to change. © 2014 Halliday + Baillie Ltd.